

DF100



Welding conn. Ø 88,9

Flange DIN Dn 80

Flange ANSI 3"

Dn 80

DIN 11851

Threaded BSP 3"

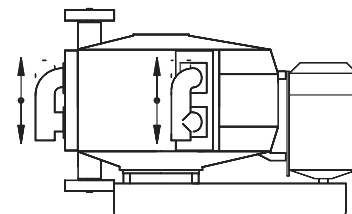
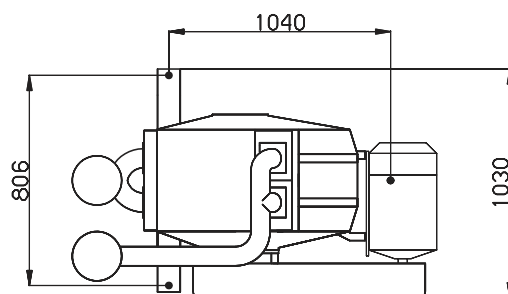
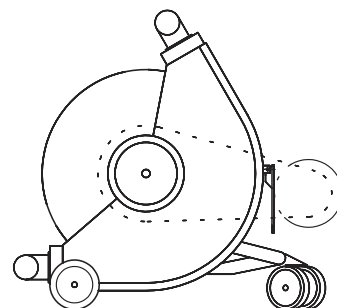
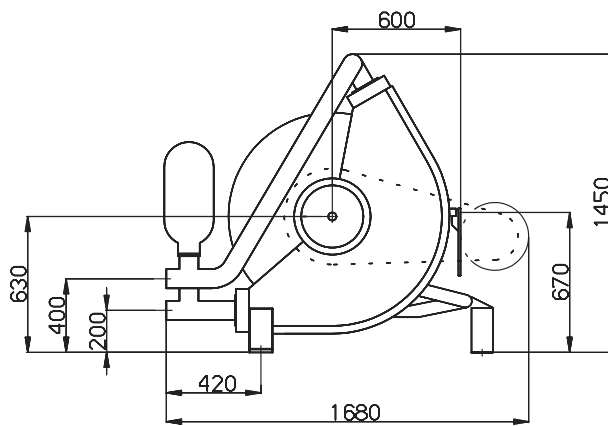

TECHNICAL DATA			
MOD.	Ø mm	LT/RPM	MAX BAR
DF	76	21	8

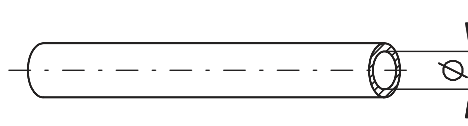

0- 3,5 bar				
RPM	Lt/h	BAR		Kw
		std	max	
14,7	17961	2	3,5	7,5
18,3	22422	2	3,5	7,5
22,1	27130	2	3,5	7,5
27,7	34068	2	3,5	11
29,2	35927	2	3,5	11
34,9	42989	2	3,5	11
43,6	53768	2	3,5	15
46	56742	2	3,5	15

4- 8 bar				
RPM	Lt/h	BAR		Kw
		std	max	
16,6	19897	4	8	11
18,5	22203	4	8	11
21	25238	4	8	15
23,5	28272	4	8	15
26,3	31671	4	8	15
29,6	35676	4	6	15
33	39803	4	6	15
37	44659	4	6	18,5
41,1	49635	4	5	18,5
46	55583	4	5	18,5

8 bar				
RPM	Lt/h	BAR		Kw
		std	max	
16,6	17468	8	8	11
18,5	19583	8	8	11
21	22365	8	8	15
23,5	25148	8	8	15
26,3	28264	8	8	15
29,6	31937	8	6	15
33	35721	8	6	15
37	40173	8	6	18,5

variable gear speed 0- 2,5 bar						
RPM		Lt/h		BAR		Kw
max	min	max	min	std	max	
20,1	3,8	24652	4456	2	3,5	7,5
25,2	4,8	30971	5695	2	3,5	9,2
30	5,7	36918	6810	2	2,5	9,2
38,2	7,3	47078	8793	2	2,5	9,2
48,1	9,1	59344	11023	2	1,6	9,2

variable gear speed 4- 6 bar						
RPM		Lt/h		BAR		Kw
max	min	max	min	std	max	
20,7	3,6	24874	4118	4	6	15
26,3	4,5	31671	5210	4	6	15
29,6	5,1	35676	5938	4	6	15
37	6,4	44659	7516	4	6	18,5
47,3	8,2	57161	9701	4	4	18,5

